

Physical Education Section
Saurashtra University, Rajkot



[Re –Accredited Grade B by NAAC (CGPA 2.93)]



Handbook of Rules and Regulations
For
Inter College Tournaments
Saurashtra University, Rajkot
2011-12

INDEX

Sr. No	Particular	Page No.
1	Introduction, Preamble, Vision, Mission & Objective	
2	Ordinance of the University, Board of Sports	
3	Constitution of Board of Sports	
4	List of the Events Organized at Inter college level	
5	Revised FISU Eligibility Rules for Participation in National University Games:2010-2011	
6	University Dress Code	
7	General Rules pertaining to the organization of Inter College Competitions and Selection Trials	
8	Rules pertaining to the selection of University team	
9	Rules governing annual athletic meet	
10	Appendix - A METHODS OF DRAW,	
11	Appendix - B ceremonies, methods & procedures to conduct ceremonies Inter Collegiate Athletics Meet	
12	Appendix – C <i>Staff Profile of Physical Education Section</i>	
13	SPORTSMANSHIP	

Physical Education Section;

Saurashtra University, Rajkot



Preamble:

Saurashtra University was established in 1967 in Rajkot city of the Saurashtra region of Gujarat State, India. It has availed of the erudition and academic experience of various distinguished educationists, beginning with the late Professor Dolarrai Mankad, the founder Vice Chancellor of the University.

Saurashtra University at Rajkot is one of the leading Universities in Gujarat. It is spread over 410 acres of land. The jurisdiction of Saurashtra University includes Amreli, Jamnagar, Porbandar, Rajkot and Surendranagar districts. The University has several colleges affiliated to it imparting Undergraduate and Postgraduate education. Apart from academic excellence Saurashtra University also boasts of a host of facilities. Separate hostels for boys and girls, gymnasium, guest house, commercial complex, party plot, book center and officer residences are some of the notable advantages that are offered by the Rajkot Saurashtra University. IGNOU and Ambedkar Open University also operates under the aegis of Saurashtra University. At present Saurashtra University is considered as one of the esteemed centers of learning in Gujarat.

Vision:

Fortification of sports and sportsmanship amongst the students of the Saurashtra University and it bearing on their firm and unflinching determination to render his valuable service to the society and nation.

Mission:

Our mission is to encourage capacity building of our physical educators and prepared affluent sports person with soaring ethical and dedicated to their duties towards building strong society and nation.

Objectives:

- To promote health, fitness awareness and encourage mass participation in Physical Education and Sports;
- To enrichment and rejuvenate physical educators of the Saurashtra University in the area of physical education and sports sciences;
- To develop and promote program of Physical Education and Sports for the students of Higher education in saurashtra university;
- To infuse in the students, spirit of competition and sportsmanship that will facilitate a healthy lifestyle;
- To closely collaborate and coordinate with the State and National bodies, in Physical Education and Sports, in matters of common interest and concern;

Chapter - I
Ordinance of the University

UNIVERSITY BOARD OF SPORTS

Ordinance 7

There shall be a University Board of Sports constituted in accordance with Ordinance 10.

Ordinance 8

The following shall be the objects of the Board, namely:

- (i) To foster and encourage sports and sportsmanship amongst the students of the University;
- (ii) To organize, control, manage and supervise Inter-Collegiate sports and tournaments within the jurisdiction of the University;
- (iii) To regulate their conduct; and
- (iv) To undertake and conduct Inter-University Competitions.

Ordinance 9 Deleted.

Ordinance 10

The University Board of Sports shall consist of the following namely:

- (i) The Vice-Chancellor.
- (ii) The Pro-Vice-Chancellor.
- (iii) Two members of the Syndicate to be nominated by the Syndicate.
 - (a) Among them one member shall be coordinator of the university Board of sports.
- (iv) Four Principals to be nominated by the Syndicate.
- (v) Three teachers to be nominated by the Syndicate from amongst the teachers of the affiliated colleges.

Note: In case if no lady Principal is nominated under Clause (iv) a lady teacher should be nominated as one of the three members to be nominated under Clause (v).

- (vi) Students Welfare Officer (Ex-Officio).
- (vii) Seven Physical Training Instructors to be appointed by the Syndicate one of whom shall be lady Physical Training Instructor.
- (viii) One Senate member to be appointed by the Syndicate.
- (ix) Four students representatives to be nominated by the Chairman, Board of Sports, every year.
- (x) Director, Physical Education (Ex-Officio).

Note: The Director, Physical Education, shall act as the Secretary, University Board of Sports.

Ordinance 11

The Principals of the Colleges and the members appointed by the Syndicate on the Board of Sports shall ordinarily be persons possessing expert knowledge or experience in a branch or branches of sports and shall hold office for three years, but shall be eligible for reappointment.

Ordinance 12

The following shall be the powers and functions of the Board, namely:

- (i) to frame rules for the conduct of Inter-Collegiate Sports and Tournaments;
- (ii) to prepare the budget for presentation to the Syndicate;
- (iii) to decide in which of the Inter-University Competitions the University should participate and prepare a budget for the expenses involved in such participation;
- (iv) to appoint Committees, to select University Teams and to conduct Inter-University Competitions whenever the University is asked to do so by the Inter-University Sports Board;
- (v) To provide for coaching in games and sports;
- (vi) To decide on appeals that may be preferred to it against the decision of a Local Tournament Committee. The decision of the Board shall be final and no appeal shall lie against its decision.
- (vii) To advice the Syndicate on:
 - (a) The Physical training of the students;
 - (b) The N.C.C. Training of the students;
- (viii) Generally to take such steps as may be found necessary for the due discharge of its responsibilities.

Ordinance 13

The Board shall meet once every six months or whenever necessary on such days as may be fixed by the Chairman. Five members shall form a quorum for a meeting of the Board.

Ordinance 14 Deleted.**Ordinance 15**

The Board may delegate to the Committees appointed by it, such powers as may be necessary for the Committees in the discharge of the duties imposed on them by the Board.

Ordinance 16 Deleted.**Ordinance 17 Deleted****Ordinance 18 Deleted.****Ordinance 19 Deleted.**

Ordinance 20

(I) The following shall be the constitution, powers and functions of the Local Tournaments Committee, namely:

- (i) The Principal of the college, which is entrusted by the Board to conduct a particular tournament, shall be the Chairman of the Local Tournaments Committee.
- (ii) The Chairman shall appoint a teacher of such a college as Secretary of the Local Tournaments Committee and send intimation to the Chairman, Board of Sports. The person to be appointed as Secretary shall ordinarily be a senior member of the staff and preferably having knowledge of the games for which the tournament is conducted by the college.
- (iii) The Secretary shall maintain all records, regarding entries, draws, fixtures and accounts.
- (iv) The Chairman of the Local Tournaments Committee shall forward all records to the Secretary, University Board of Sports within ten days after the conclusion of the tournaments.
- (v) The Local Tournaments Committee shall consist of the following members :
 - (i) The Chairman,
 - (ii) The Secretary,
 - (iii) Three other members one of whom shall be preferably an expert in the games for which the tournament is conducted by the college.
- (vi) The Committee shall have powers.
 - (a) to frame rules for the conduct of the respective games in accordance with the rules laid down by the Board of Sports.
 - (b) to decide on appeal that may be preferred to it in respect of the games for which the tournaments are being conducted and to forward the decision for information of the Board of Sports.
 - (c) to do all other things as may be necessary for the efficient conduct of the tournaments.
- (vii) Each Local Tournaments Committee shall decide the manner in which tournaments will be conducted.
- (viii) The head of every competing institution shall submit to the Local Tournaments Committee concerned, a list of the names of the players from which the players will be selected for participation and the necessary eligibility details shall also be supplied on the dates fixed by the Chairman of the Local Tournaments Committee. The head of the competing institution shall be responsible for the veracity of the

eligibility details. The details once submitted will not be allowed to be altered subsequently by the institution concerned.

(II) (a) The entries for athletics competition shall be submitted to the Secretary, Board of Sports on or before the date fixed by the Secretary. They shall be in the prescribed forms supplied to the colleges by the Secretary at least ten days prior to the last date for receiving the entries.

(b) The last date fixed for submitting entries for any tournaments or athletics shall not be altered, except with the permission respectively of the Chairman, Local Tournaments Committee and the Chairman, Board of Sports.

Ordinance 21 Deleted.

Ordinance 21-A

If a student of a University department or a post-graduate centre directly run by the University desires to play in any of the games at the Zonal or Inter Zonal level, he shall be allowed to do so from a local college on production of a no objection certificate from Head of the respective Department or post-graduate centre and further provided that the local college is willing to send him as its player for the game concerned. But it shall be the responsibility of the said college to prepare all details required for enabling the students to play in the game.

"The power of the human will to compete and the drive to excel beyond the body's normal capabilities is most beautifully demonstrated in the arena of sport." ---Aimee Mullins

Chapter - II

Constitution of Board of Sports

The University Board of Sports shall consist of the following namely:

- (i) The Vice-Chancellor. (Chairman)
- (ii) The Pro-Vice-Chancellor.
- (iii) Two members of the Syndicate to be nominated by the Syndicate.
 - (a) Among them one member shall be coordinator of the university Board of sports.
- (iv) Four Principals to be nominated by the Syndicate.
- (v) Three teachers to be nominated by the Syndicate from amongst the teachers of the affiliated colleges.

Note: In case if no lady Principal is nominated under Clause (iv) a lady teacher should be nominated as one of the three members to be nominated under Clause (v).
- (vi) Students Welfare Officer (Ex-Officio).
- (vii) Seven Physical Training Instructors to be appointed by the Syndicate one of whom shall be lady Physical Training Instructor.
- (viii) One Senate member to be appointed by the Syndicate.
- (ix) Four student's representatives to be nominated by the Chairman, Board of Sports, every year.
- (x) Director, Physical Education
(Ex-Officio, Secretary, University Board of Sports).

Note: The Director, Physical Education, shall act as the Secretary, University Board of Sports.

Chapter - III

List of the Events Organized at Inter College Level



Sr. No.	Name of the Sports and Games
1	<i>Football (M)</i>
2	<i>Hockey(M & W)</i>
3	<i>Kabaddi (M & W)</i>
4	<i>Volleyball (M & W)</i>
5	<i>Basketball (M & W)</i>
6	<i>Tennis (M & W)</i>
7	<i>Table Tennis (M & W)</i>
8	<i>Handball (M & W)</i>
9	<i>Softball (M & W)</i>
10	<i>Kho-Kho (M & W)</i>
11	<i>Archery (M & W)</i>
12	<i>Rifle Shooting (M & W)</i>
13	<i>Weight lifting and power lifting (M & W)</i>
14	<i>Wrestling (M & W)</i>
15	<i>Swimming, Diving and Water polo (M & W)</i>
16	<i>Gymnastics (M/W)RG (W) Mallkhambh (M & W)</i>
17	<i>Athletics (M & W)</i>
18	<i>Cricket (M & W)</i>
19	<i>Cross Country (M & W)</i>
20	<i>Cycling (M & W)</i>
21	<i>Judo (M & W)</i>
22	<i>Badminton (M & W)</i>

Chapter - IV



Saurashtra University, Rajkot



**ASSOCIATION OF INDIAN UNIVERSITIES
(Inter University Sports Board of India)**

**Revised FISU Eligibility Rules for Participation in National University Games:
2010-2011**

A. Eligibility Rules:

Only a bonafide student, who is currently officially enrolled / registered for a degree or diploma at the university / college whose status is recognized by the appropriate authority of the country, which is of a minimum duration of one academic year and whose examination is conducted by the university shall be eligible to participate in National University Games.

1.1 Students of Open Universities and Institutes of Open Learning shall be considered to be bonafide and eligible to participate in National University Games. However, students enrolled/registered in Correspondence Course Institutes of Universities shall not be eligible to participate.

1.2. Ph.D. and M. Phil. students will be eligible to participate only if in terms of the concerned University's rules they are regarded to be bonafide students and fulfill other conditions laid down in this behalf.

2. All eligible students while participating in National University Games shall fulfill the following conditions:

(a) Not more than 9 years have elapsed since a student passed the examination qualifying him/her for first admission to a degree or diploma course of university or college affiliated to a university.

(b) The nine year eligibility period mentioned above shall be distributed as under:-

i. not more than 5 years after passing qualifying examination/ 10+2 examination or equivalent examination, the period of 3 years shall be extended by two years more than the actual length /duration of the course.

ii. not more than 4 years after passing Graduate Course/Degree, in Post Graduate Courses. However, the period of two years shall be extended by two years more than the actual length/duration of the course. This period includes M. Phil and Ph. D courses too.

irrespective of any other conditions like change of class/course/faculty, joining lower class from higher, changing academic to professional courses or vice versa, provided that:-

students admitted, immediately after passing 10+2 examination, to graduate courses of more than 3 years duration like Medical, Engineering, Agriculture, Pharmacy and Physical Education etc. shall be eligible to participate in National University Games for one year more than the actual length/direction of such graduate courses.

For the purpose of determining the number of years under the revised FISU eligibility rules for participation:-

- a). graduate courses shall be treated to be those where the admission is sought after passing 10+2 or equivalent examination, as the case may be.
- b). all other professional courses where admission is obtained after passing graduate degree examination(s), e.g. LL.B., MBBS, BCA, BBA .B.Ed., BP. Ed & B. Lib. etc. will be clubbed with other postgraduate courses like M.A., MBA, M.Sc., M.Com., M. Lib., M.Ed. & M P. Ed etc, as the case may be.

Only the competitors who satisfy the following conditions are considered to be eligible to participate in National and International University Games:

Be a national of the country they represent;

Only student who are less than 28 years of age as on first July of the academic year in which the tournament is held, can participate.

4. A student who is employed on full time basis will not be considered eligible to participate in National/International University Games/Championships. However, the student(s) who receive salary or stipend, as the case may be, from Public and Private Sectors can also participate in National University Games provided he/she submits "No Objection Certificate" (NOC) from the respective Department /Organization categorically stating that he/ she is permitted to participate in National /International University Games while pursuing his/her studies before his/her admission in a college / university is regularized.

5. A student shall not be allowed to represent more than one university in National University Games during a single/ same academic year.

6. Provisional admission to a course of university or college shall not make the student(s) eligible to represent the university in National University Games.

7. In case of a student migrating from one University to another, his/her migration case will be considered eligible only after his/her admission in the

new university is regularized and he/she is admitted as a bonafide and eligible student by the new University.

B. Explanation

- i. In case of student(s) changing from one course to another the period spent in the previous course before joining the new course shall be counted towards total period of eligibility while participating in National University Games.**
- ii. One year means the academic year in which the tournament is held irrespective of whether the student's result is declared or not. It will normally extend from 1st July of one year for 12 calendar months to the next year.**
- iii. A bonafide student may not be considered to be eligible to participate in National University Games if he/she does not pass/qualify a particular class within the period of two years, both at Graduate and Post Graduate courses. However, duration/ length of the courses will remain unchanged. For example, not more than five *years* while students are pursuing Graduate Course/Degree and not more than four *years* while they are pursuing Post Graduate Course/Degree including M .Phil or Ph.D., as the case may be.**
- iv. Interchange of faculty may be allowed to participate, provided the student passes his/her first year of class/course. If the candidate participates for two years in one particular class and if he/she changes course for the identical year, he/she may not be eligible to participate in National University Games for the remaining period of his/her eligibility unless he/she passes first year of the course.**
- v. Student(s) joining lower class/course from higher professional course/degree, merely for the sake of participation or winning sporting competitions will not be encouraged at the cost of academic qualifications essentially required for better career prospects of elite athletes.**

C. Disqualification for Violation of FISU Eligibility Rules

- 1. Any disqualification of a sportsperson on the grounds of ineligibility will result in automatic scratching of his/her team, for that academic year. The team may be debarred from participating in the National University Games (in that game/event) to be held in the following year, if necessary.**
- 2. A sportsperson disqualified on the basis of ineligibility shall not be permitted to participate in National University Games in the next year, if necessary.**
- 3. It shall be obligatory for the sportspersons, who are selected to represent Indian Universities Team(s) for participation in National /International**

University Games, if they represent some other organization/state without the permission of AIU, and their respective university/college, they shall be debarred from participation in the National University Games and disciplinary proceeding shall be initiated according to the existing rules.

4. It shall be mandatory for those students who joined Private or Public Sector(s) on stipend, while pursuing their study in universities/colleges to participate in Inter College and Inter University Sporting Competitions, in case their admission is based on the sports quota earmarked for promotion of sports by the appropriate authorities should seek no objection certificate from the concerned sector.

5. Further, in case of incidents of violence during sporting competitions, the College/ University authorities shall have the power to cancel the admission of the defaulting sportsperson(s), if found guilty after due process of enquiry.

6. The defaulters of Drug abuse (doping) in University Sports shall be debarred from participation in the National and International University Games for minimum of period of three years based on the gravity/ intensity of offence established by the National Anti Doping Agency (NADA) with a view to make sports drug free in India.

"Sports remain a great metaphor for life's more difficult lessons. It was through athletics that many of us first came to understand that fear can be tamed; that on a team the whole is more than the sum of its parts; and that the ability to be heroic lies, to a surprising degree, within." ---Susan Casey

Chapter IV

University Dress Code

The University will provides Sports Uniforms i.e. track suits and sports dress Kit (T shirt & Short / Banyan & Short) to all the students who are selected and going to take part in Inter-University Tournaments once in a year or the amount for the Sports Uniforms will be paid to the sport person against produce of cash vouchers. The amount will be paid as per the rules pertaining to the rate of amount decided by the Board of Sports time to time. The color combination and design will be decided by Board of Sports time to time for the unique identity of the University team.

Sports Dress Kit

Sr. No.	Name of the Sports and Games	Uniform for male	Uniform for female
1	Football	T Shirt & Short	-
2	Hockey	T Shirt & Short	T Shirt & Short
3	Kabaddi	T Shirt & Short	T Shirt & Short
4	Volleyball	T Shirt & Short	T Shirt & Short
5	Basketball	T Shirt & Short	T Shirt & Short
6	Tennis	T Shirt & Short	T Shirt & Short
7	Table Tennis	T Shirt & Short	T Shirt & Short
8	Handball	T Shirt & Short	T Shirt & Short
9	Softball	T Shirt & Short	T Shirt & Short
10	Kho-Kho	Banyan & Short	T Shirt & Short
11	Archery	T Shirt & Short	T Shirt & Short
12	Rifle Shooting	T Shirt & Short	T Shirt & Short
13	Weight lifting and power lifting	T Shirt & Short	T Shirt & Short
14	Wrestling	costume	T Shirt & Short
15	Swimming, Diving and Water polo	costume	costume
16	Gymnastics (M/W) RG (W) Mallkhambh (M) / RM (W)	costume	costume
17	Athletics	T Shirt & Short	T Shirt & Short
18	Cricket	White Pent	White Pent
19	Cross Country	T Shirt & Short	T Shirt & Short
20	Cycling	T Shirt & Short	T Shirt & Short
21	Judo	T Shirt & Short	T Shirt & Short
22	Badminton	T Shirt & Short	T Shirt & Short

"To achieve in sports you first have to have a dream, and then you must act on that dream. The best athletes are those who truly enjoy what they are doing and display a tremendous amount of work ethic. They continue to persevere in spite of setbacks and never lose sight of their ultimate goal." ---Dianne Holum

Chapter V

General Rules pertaining to the organization of Inter College

Competitions and Selection Trials

1. The Board of Sports of Saurashtra University shall have power to include or exclude any of the inter college competitions of the sports & games listed in chapter III. The Date and Venue of the inter college tournaments shall be fixed and approved by the Board of Sports every year.
2. The inter college competition calendar and venue will prepared and approved by the Board of Sports as per the Dates available and approved by the AIU for All India and Zonal Level Inter University Tournaments.
3. Competition calendar for Inter-University and Inter College Tournaments will be made available on web space of physical education section of the University website and also it is circulated in all affiliated colleges for the student's information. All the affiliated colleges has to keep it on the college notice board up to last date of the inter college competition.
4. All the Inter College Tournaments must be organized by the qualified workforce by the host college and entire tournaments must be refereed /umpired / Judged by qualified technical officials and / or approved by the board of sports of the particular sports and games.
5. No affiliated colleges are allowed to take parts in any inter college competitions in which they are participating any sports and games without a qualified physical educators.
6. All affiliated colleges should send their entry directly to the organizing colleges and one copy to the Director of Physical Education and Sports, physical education section, Saurashtra University, Rajkot.
7. While drawing fixture, at least representatives of first four colleges in order of merit of previous year in each sporting event should be invited through speedy communication to maintain transparency in the conduct of inter college tournaments.
8. The affiliated college must send their students with proper uniforms to take part in inter college tournaments. The students are not allowed to take part in any of the inter college tournaments in civil dress.
9. Organizing secretary of the college of inters college tournaments must send detail report of the competition and expenditures made during the competition within fifteen days to the Director of Physical Education and Sports, physical education section, Saurashtra University, Rajkot.
10. Appointments of the Umpires/ Technical Officials & their powers and responsibilities:

- Neutral Umpires/ Technical Officials / Referees generally appointed by the Board of Sports. The chairmen or organizing secretary of inter college tournament of organizing college can also appoint neutral Umpires / Technical Officials / Referees with the consents of Director of Physical Education and Sports of Saurashtra University, Rajkot in the case of any urgency.
 - All the physical educators working in the affiliated colleges of the university should consider as a technical official.
 - The Umpires/ Technical Officials / Referees must be refrain to work as a member of selection committee if he or she directly or closely connected with any sports person as a relative (Blood Relation) or for his own college team is playing in the ground.
 - All Umpires/ Technical Officials / Referees appointed by the organizing secretary, or secretary, Board of Sports or must be refrains from using unfair means during selection of the university team.
 - All Umpires/ Technical Officials / Referees appointed as a member of selection committee must be work with honesty to select best university team and maintain dignity during selection process of the university teams.
 - Only the qualified Umpires/ Technical Officials / Referees are allowed to work as a referee of the Inter college tournaments.
 - Other then PET's of the affiliated colleges of Saurashtra University Umpires/ Technical Officials / Referees must have state level qualification of particular sports and games.
11. **Procedure of Protect against the decisions of Umpires/ Technical Officials / Referees and / or Member of selection committee:**
- Protests against the decisions of Umpires/ Technical Officials / Referees/ selection committee members on a point of law or any other matter shall be made in writing within the 2 (Two) hours after the completion of the specific tournaments or selection trials must reached to the person in-charge of the games / organizing secretary of the particular tournaments or selection trials of sports and games along with the protest fees of Rs. 250/-only to the organizing secretary of the tournaments. The protest fee shall be forfeited if the longed protest is not sustained. The detailed reports regarding each protest should be reached to the secretary, Board of Sports immediately after the completion of the said tournament. Pl. Note: (Any team leaving the field of play under protest shall be deemed to have lost the match and forfeited its right to protest)
12. **Remuneration, Travelling and other Allowances:**
- Travelling allowances of the members of the Board of Sports and Committee for attending meeting called by the Board of Sports for transaction of business connected with the University will be paid as per Appendix - D
- The Players, managers and coaches of university teams proceeding for Inter-University tournaments will be paid as per Appendix - D

- Halting allowance of the out –station coach appointed for coaching University team will paid by the university as per the rules and travelling, daily allowances and incidental charges will be paid as per Appendix – D

13. Seeding and Conduct of the Draw:

- The draw shall be conducted following manner where the tournaments are to be played on a knock out basis.
- The name of each college shall be written on a separate card or paper and these shall be placed in a bowl or hat, drawn out one by one at random and written on another paper in the order in which they have been drawn, provided that in cases where particular colleges have entered two players or paired in the singles or doubles even respectively, the 'A' and 'B' entries shall be put into separate halves. (See Appendix – B for the details.)

14. Method and Draw: The method of draw is given in Appendix – A.

15. Trophies and Certificates:

- The trophies shall be property of the University and in any kind of consequence trophies not in actual use shall be kept in the custody of the University.
- It shall be incumbent on the institution holding any of the trophies to send them at its own cost to the institution undertaking to conduct the Inter-College Annual Athletic Meet, for award to new winner. This should be done well before the one month of the date fixed for the Annual Athletic meet by the University.
If tournament is not being held in any calendar year, the trophy for the same will be not awarded; in that case the trophy shall be sent to the Secretary Board of Sports. All those institutions who received rolling trophies shall be held responsible for the safety and care of the trophies. Any damage to or lose of trophy should be reported promptly with relevant details to the secretary of the University Board of Sports.
- Certificates of merit signed by the Vice-Chancellor shall be awarded to the individual members who have actually participated in finals of the tournaments of different games (Team Games), and for Individual and Combative Sports players securing first three places like Athletics, Aquatics, Diving, Wrestling, Weightlifting, Gymnastics, Archery, Rifle shooting and Judo etc.

16. Tournament Rules:

- A team or any player of the team misbehave and use any unfair means on the field a team or player shall be debarred from further participation in the tournament by the Tournament Discipline Committee. The results of the previous matches will not be distributed. The matter should be reported in detail to the Board of Sport for such action as the Board deems fit.
- The decision of the umpires or referees on all points of fact shall be binding and final.

- No match shall be postponed unless the tournament committee decides. In exceptional circumstances, the power to postpone a match is vested in the persons-in-charge of the tournament/ Organizing Secretary.
- The Chairman of the sub-committee or tournament committee shall not normally postpone any match unless an application for postponement with reasons thereof has been received by him at least twenty four hours before the commencement of the match, the postponement of which is desired, and unless he is satisfied with the reasons mentioned.
- No match shall be postponed unless each the participating institutions has at least twelve hours previous notice of such postponement in writing. When any participating team has to travel, the intimation of postponement should be at least forty eight hours before the match.
- Any team that is late by more than 30 minutes shall be scratched unless the tournament committee decides otherwise. The team that is present shall be given a walkover.
- Entries should reach the organizing secretary before twelve noon on the date fixed for the receipt of the entries. Entry Fee Rs.50/-for all games and For Cricket (M & W) is Rs.200/-
- Entries received after the draw is held as per the rules under any circumstances the entry shall not be accepted by the tournament committee.
- If intimation regarding a walkover by the participating college is not given in three clear days before the day of commencement of the match, and the institution received walkover will have to bear the expenses for that match and such expenses shall have to be paid before further participation in the same or any other tournament.
- In the case of impersonation of one player by another in a team
 - (a) The team shall be debarred from all further participation in the tournament, and
 - (b) The player impersonated, the impersonator and the captain shall be debarred from participation in all games & sports for a term of two years, the results of the previous matches however, will not be distributed.
- If a protest is lodged prior to or during match, the match shall be played out. A team which abandons a match for any reason will be considered to have conceded the match.
- Any team conceding a match at any stage shall be debarred from further participation in the tournament.
- The eligibility details should reach the organizing college a week in advance.

16. Inter college Tournaments:

- Inter-Collegiate Tournament in Tennis, Badminton and Table Tennis.

For Tennis and Badminton, the singles champion of the College, the doubles champion pair and the second best singles players of the college shall comprise the college team.

(For this at the Inter-College level, there should be two separate tournaments in singles and doubles. If the tournament is conducted on team basis, ranks should be given to individual players)

In table tennis which is to be played on swathing cup lines, the Inter Collegiate Team shall comprise first 4 singles (individual players) out of which 3 will represent the college in the tournaments.

For all teams, games played on leagues basis, the point for deciding the place will be awarded on the following basis.

- For games like Volley-ball Badminton, etc. where the result of the match is decided by the best 3 to 5 games, the winner will get 2 points and the loser will get zero. In case of an equal number of points between the two teams, the winner amongst them in their match will be the winner.
 - (i) For Cricket, which is to be played on a knock out basis the winning college team will be awarded 8 points, and the runner up team will get 4 points.
 - (ii) For games like Foot-ball, Hockey, kabaddi, Basketball, etc. where the game consist of 2 innings of fixed time duration, and whose tournaments are to be played on a league basis, the winner will receive 2 points and the loser will get 0 point. If the game is a draw one, each team will receive a point each. The first, second and third place will be decided on the total points thus receive an equal number of points at the end, the place will be decide by the goal or points average as the case may be (the goal or points average is the ratio of the goals or points scored by the team and the goals or points scored against them by other teams).
- If the tournaments are played on knock-out basis the result would be self-explanatory.
- The points will be awarded as under :
 - Team Game : Winner - 8 , Runners up - 4
 - Individual Game : First Three place -5-3 & 1
 - (Athletics, Aquatics, wrestling, Boxing wt. Lifting etc.)
- Points are to be awarded only if three teams actually participate in the games. Mere sending of entry will not be taken into account. For conducting a tournament in any game there should be at least five entries received.

17. Inter University Tournaments :

- The University may participate in inter University sports and tournaments in as many games and items as may be recommended by the Board of Sports.
- The selection of a University team and its Captain shall be made by selection committee appointed by the Board of Sports.
- The Professors or other persons appointed to accompany the team proceeding to compete in Inter-Collegiate, University or Inter-University competitions, should travel with the team not necessarily in the same boggy stay with of near the team, and should be in constant touch with the members of the team until they return to headquarters.

- All the players of different participating colleges should wear printed chest numbers on the banyan(9*6 inches size) or T – shirts (9*6 inches size) on the chest and back of upper extremity (Upper Body). It is compulsory during the inter college tournaments and selection trials for the following games given below:

Football, Hockey, Basketball, Volleyball, kabaddi, Kho-Kho, Handball, Softball

BADMINTON, TABLE TENNIS AND TENNIS

- The competition shall be conducted under International Federation Rules as adopted by the National federations of India.
- Only two players can represent from each college. i.e. If tournament is for Boys & Girls can sent 2 Boys + 2 Girls player
- Only singles tournament will be conducted and first four will be selected for Inter University team.

BASKET-BALL

- Inter-University Rules in basket-ball shall be followed with regard to Rules and Timings.
- Inter – Collegiate Tournament may be conducted on knock-out-cum-league basis.

FOOT-BALL & HOCKEY

- Matches shall be played according to the rules of the All India Foot-ball and Hockey Federation as adopted by the Inter-University Sports Board.
In case of a drawn match one point will be awarded to each team. In case of the equal number of points, for a place it will be decided by the goal average. In case of three teams playing a league if one of them gives a walk over to any other, the match between the other two will be decided on the knock-out basis.
- No team shall be forced to play two matches on the same day except when games are down, and there shall be a gap of at least 8 hours between two matches played on the same day. As far as possible, no team shall have to play on more than two consecutive days except in case of drawn matches.
- No player shall be permitted to participate in a football tournament without foot-ball boots.

KABADDI

- The Kabaddi tournament will be run in accordance with the rules of Kabaddi Federation of India.

KHO-KHO

- The Kho-Kho Tournament will be run in accordance with rules of Kho-Kho Federation of India.

SWIMMING

- The rules followed in the Inter-University to moment shall follow in those items as are decided by the Board of Sports from time-to-time.

WRESTLING

- The Wrestling Tournament shall be played as per Inter University Tournament Rules, as decided by the Inter-University Sports Board.

- The competitions will be held in the following standards weights :
 - Upto 50 Kg.
 - Upto 55 Kg.
 - Upto 60 Kg.
 - Upto 66 Kg.
 - Upto 74 Kg.
 - Upto 84 Kg.
 - Upto 96 Kg.
 - Upto 120 Kg.
- Each college may enter two competitors in each weight category with one substitute. The two Competitors from the same college will be placed in the separate halves at the time of draws.

WEIGHT LIFTING

The weight Lifting competitions shall be conducted as per the Inter-University Competition Rules, as decided by the Inter-University Sports Board.

The Competition will be held in the following standard weights.

WEIGHT LIFTING

	MEN	WOMEN
Upto	56 Kg.	48 Kg.
Upto	62 Kg.	53 Kg.
Upto	69 Kg.	58 Kg.
Upto	77 Kg.	63 Kg.
Upto	85 Kg.	69 Kg.
Upto	94 Kg.	75 Kg.
Upto	105 Kg.	+ 75 Kg.
Upto	+ 105 Kg.	-----

Each college may enter two competitors in each weight one substitute.

POWER LIFTING

	MEN	WOMEN
Upto	52 Kg.	44 Kg.
Upto	56 Kg.	48 Kg.
Upto	60 Kg.	52 Kg.
Upto	67.5 Kg.	56 Kg.
Upto	75 Kg.	60 Kg.
Upto	82.5 Kg.	67.5 Kg.
Upto	90 Kg.	75 Kg.
Upto	100 Kg.	82.5 Kg.
Upto	110 Kg.	90 Kg.
Upto	125 Kg.	+ 90 Kg.
Upto	+ 125 Kg.	-----

CRICKET (MEN)

- Matches shall be played according to the M.C.C. Rules as adapted from time to time from the Cricket Control Board in India unless otherwise modified in these rules.
- All matches are conducted as follows :
 - (a) Up to all matches 50 Limited over which be completed by each side
 - (b) In all matches the period of play shall be six hours every day.
 - (c) If there is a tie, the issue will be decided by the spin of a coin.
- The umpire charge will be borne by the participating colleges up to semi-finals. For the finals the umpire charge will be borne by the University.
- The T.A. and D.A. to umpires for all matches will be borne by the University as per Norms decided by BOS time to time

VOLLEY BALL

- The international rules as adopted by the Volley Ball Federation of India shall be followed, unless otherwise modified in these rules.
- Inter Collegiate Tournament may be conducted on Knock- out-cum-league basis.

CHESS

- Rules of the Chess Federation of India shall apply to the Inter University and Inter Collegiate Chess Tournament unless, otherwise, modified in these rules.
- The tournament will played according to the Swiss method (Six Round)
- The chess clocks shall be used if available.

Other Games: Judo/ Cross Country/Soft Ball

All tournaments in games not mentioned above will be conducted under the Inter University Rules as frames or adopted by the Inter University Sports of Board time to time.

NOTE : All the tournaments i.e. Inter University and Inter-Collegiate tournaments will be conducted under the Inter University Rules as framed or adopted by the Inter University sports Board of India from time to time.

Gymnastics and Malkhanbh

- The rules followed in the Inter-University to moment shall follow in those items as are decided by the Board of Sports from time-to-time.
- The competition shall be conducted under International Federation Rules as adopted by the National federations of India.

Archery / Rifle shooting

- The rules followed in the Inter-University to moment shall follow in those items as are decided by the Board of Sports from time-to-time.
- The competition shall be conducted under International Federation Rules as adopted by the National federations of India.

18. Rule governing to Annual Athletics Meet:

- The University Annual Athletic meet shall be held every year on dates preceding the Inter-University Athletic Meet.
- The Date and Venue of the inter college tournaments shall be fixed and approved by the Board of Sports before the end of August every year.
- No students shall be permitted to participate in the University Athletic meet unless he has attained the qualifying standard laid down by the Board of Sports.
-
- Each college or institution shall submit entry in the prescribed form provided by the physical education Section of Saurashtra University. All participating colleges have to submit information of participants like total members' participant in each event, number of participants in each event and the record of each of them in each event. In running events, the timings of the first three competitors shall be supplied to the Organizing Secretary for the University tournament.
- The Competition shall be conducted as per rules and regulations of adopted by the Amateur Athletic federation of India.
- **EVENT FOR MEN :**

Races: 100, 200, 400, 800, 1500, 5000 & 10,000 Meters Decathlon, Half Marathon and 20 Km. Walk.

Relay Races: 4*400 Meters, 4*100 Meters.

Hurdles: 110 and 400 Meters.

Jumps: Board, High, Hop-Step, and Pole-vault,

Throws: Shot, Hammer, Discus and Javelin.

- **EVENT OF WOMEN:**

Relay races: 4*100 Meters & 4*400 Meters

Races: 100, 200, 400, 800, 1500 and 5000, 10,000 & Meters pentathlon.

Hurdles: 100 Meters and 400 Meters.

Jumps: Broad, High & Hop Step, Pole-vault.

Throws: Shot, discus, Javelin and Hammer.

- Each Colleges may send Maximum two competitors for each Athletic Event and one team for the relay races, the total, however, not to exceed 15 competitors (8-Boys - 7-Ladies) plus two managers one for gents and one Ladies for the

combine team. Amongst them one must be a qualified physical Education of the college said than five events.

- The order of Athletics events shall be fixed and notified in advance to all the Participating colleges by the University.
- Duration: The competitions may be held on two successive days with morning and afternoon session.
- The members of the selection committee will be paid T.A.D.A. as per Appendix-D by the committee.
- No team will allowed taking part without designated physical educator of that participating college.
- Last date of Entry: The last date for entries shall be fixed by the Board of sports No entries shall be accepted after closure of entries.
- Points: Points shall be awarded event-wise. The athlete and his college shall score for the first place five points, on each event, three points for the second place, and one point for the third place. In the relay races, however, the winner college shall score 10 for the first, six for the second and two for the Third place.

The Points for the places will be awarded if there are four competitors or more, If there are less than four, points for only first two places will be given.

- Ties: when two individuals tie in any event, the tie shall be broken according to the rules of the International Amateur Athletic federation.
 - A. Championship: the college securing the highest number of Points at the end of the competition shall be declared the champion college respectively, for the year, for college championship, relay points will not be considered. In case of a tie for the Champion College, the one which has a greater number of first places to its credit shall be adjudged the champion. If a tie still persists, than the college in which has larger number of its team member's points win the championship.
- **Record: University record to be recognized must be accepted and rectified by the Board of sports. No record shall be recognized unless made under standard specification of Equipment and its Measurements as per the AAFI and or AIU Sports competition rules. There must be records sheets and application form with the duly signed by well qualified technical officials of respective events.**
- The colleges shall have their flags which shall be carried by the term representing the college at the Inter-Colleges Sports & Tournaments.
- The captions of the teams shall be standard players.

RULES PERTAINING TO THE SELECTION OF UNIVERSITY TEAM

- (1) The selection trials for the University team to participate in the Inter-University Tournaments will be held at the place decided by the Secretary Board of Sports with the consent of Board of Sports.
- (2) The University Board of Sports shall appoint different committee consisting of 3 to 5 members for the purpose. The Chairman of these committees will be one of the members of Board of Sports and other members will be experts in these games available, as far as possible, from the University area. The Secretary of the University Board of Sports will be an Ex. Officio member of these selection committees over and above the members appointed by the Board of Sports.
- (3) However, If coaching camps in games during the periods as fixed by the Board of Sports are hold for the players from different Colleges, University team in these games may be selected during these coaching periods without going thought the procedure prescribed above.
- (4) The travelling, boarding and lodging expenses of the students coming for selection trials will be borne by the respective participating college.
- (5) The travelling, Boarding and lodging expenses of the students who are taking part in combined coaching camps and student's those who are going to participate in All India / Zonal Inter-University Tournaments will be borne by the University as per Appendix-?. Item No.?
- (6) In the case of Cricket selection trials, the number of players as decided by the secretary, Board of Sports will be invited.
- (7) The number of players to participate for Inter University Tournaments will be as under.

**Total Number of the players allowed to represent at Inter University
Competitions as per AIU Norms**

No.	GAMES	No. of Players
1.	Cricket (M & W)	16 +16
2.	Foot Ball (M)	18
3.	Hockey (M & W)	16 +16
4.	Volley Ball (M & W)	12 +12
5.	Basket Ball (M & W)	12 +12
6.	Hand Ball (M & W)	12 +12
7.	Kabaddi (M & W)	12 +12
8.	Kho-Kho (M & W)	12 +12
9.	Soft-Ball (M & W)	15 +15
10.	Tennis (M & W)	4 + 4
11.	Table-Tennis (M & W)	4 + 4
12.	Badminton (M & W)	4 + 4
13.	Chess (M & W)	5 + 5
14.	Swimming (M & W)	12 As per qualifying standard
15.	Gymnastics(M&W), RG(W), Mallkhambh (M&W)	5+5+3+3+3 As per qualifying standard
16.	Wrestling	10 As per qualifying standard
17.	Weight Lifting & Power Lifting	12 As per qualifying standard
18.	Cross Country Race (Men & Women)	15 As per qualifying standard
19.	Judo (Men & Women)	20
20.	Athletics (Men & Women)	15 As per qualifying standard
21.	Archery	As per AIU norms
22.	Cycling	4+4 (Road race & team events)
23.	Rifle shooting	As per AIU norms

Appendix - A

METHODS OF DRAW

Abbreviations Used

- W = Winners of previous year
 R = Runners-up of previous year
 LAW = Losers Against Winner of previous year.
 LAR = Losers Against Runners up of previous year

In the case of number of participating team are 5.

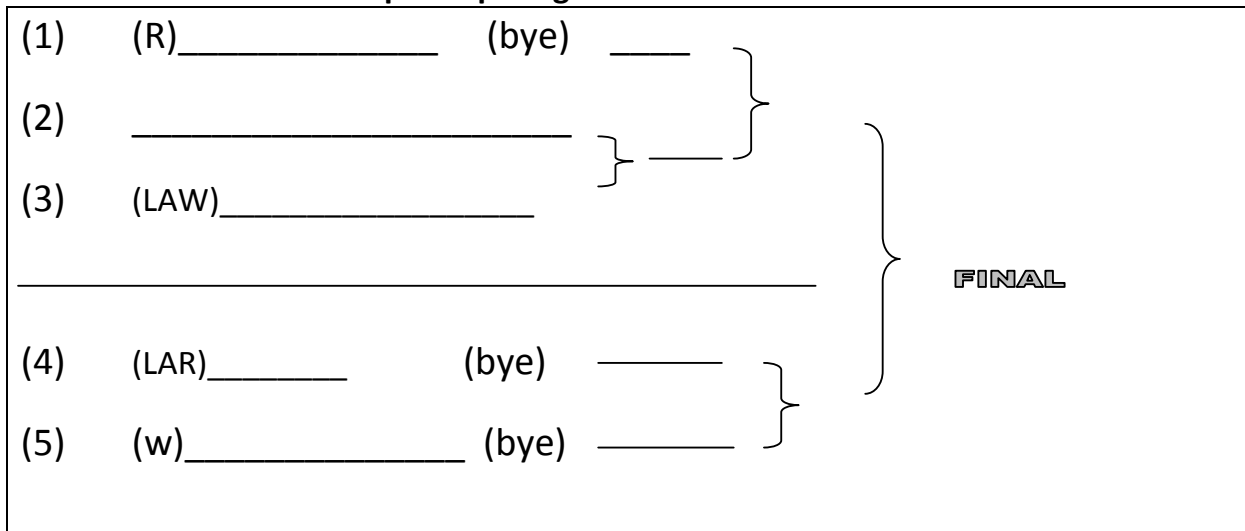

With 6 teams

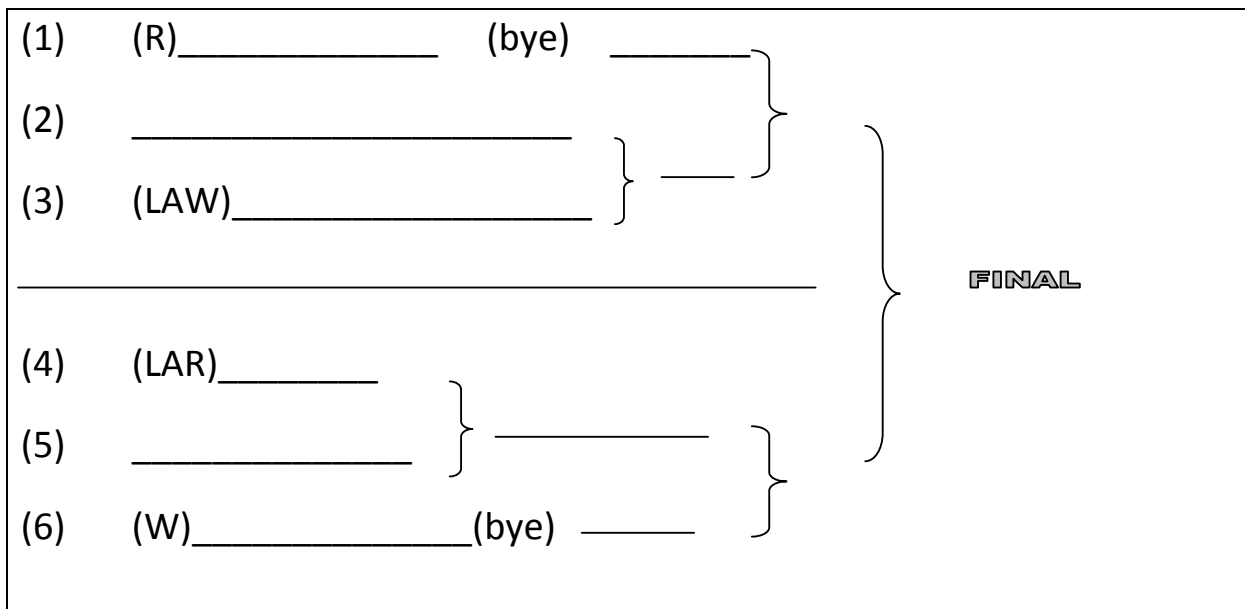

With 7 teams

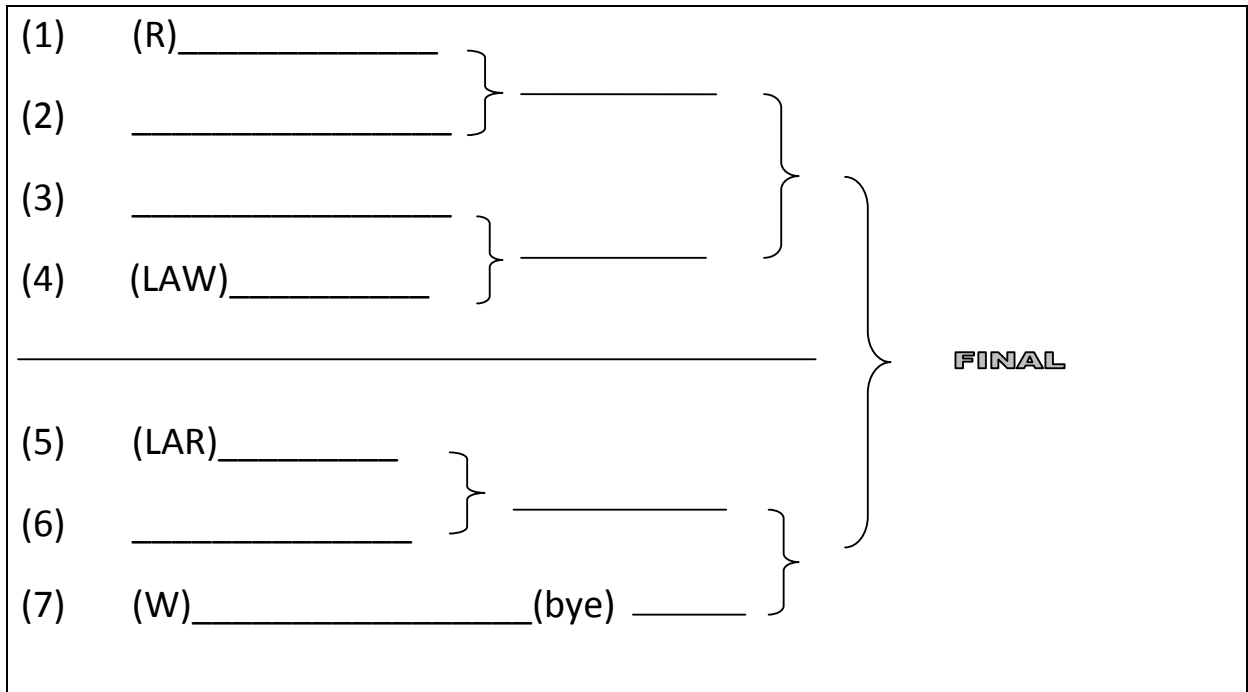

With 8 teams

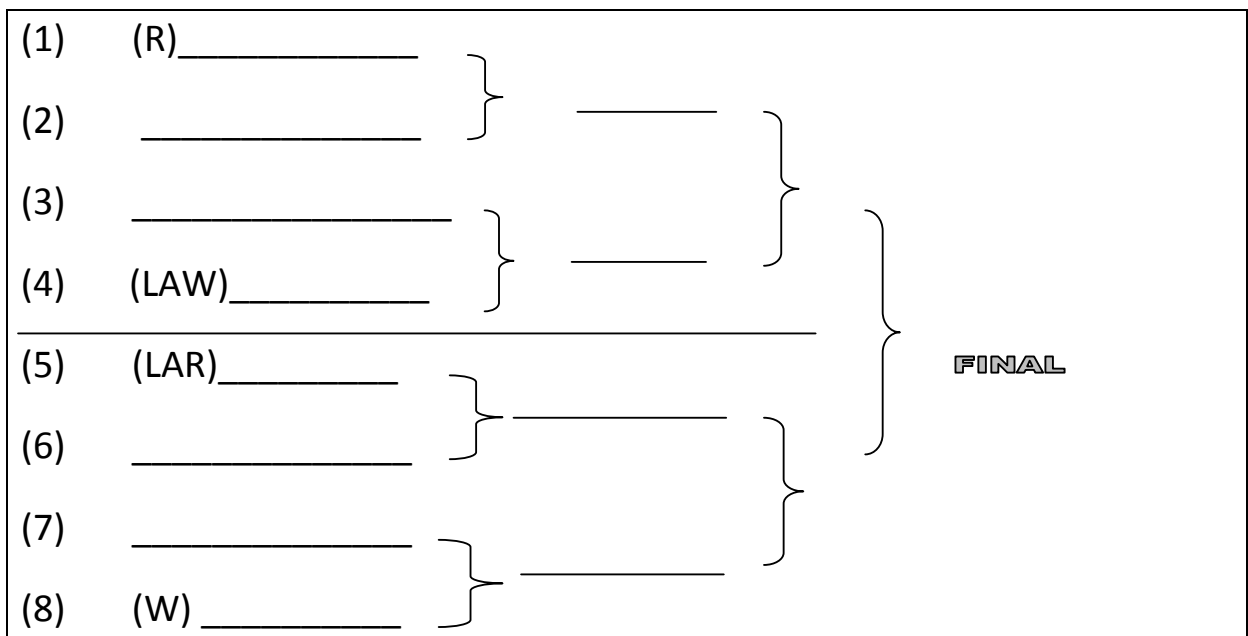

With 9 teams

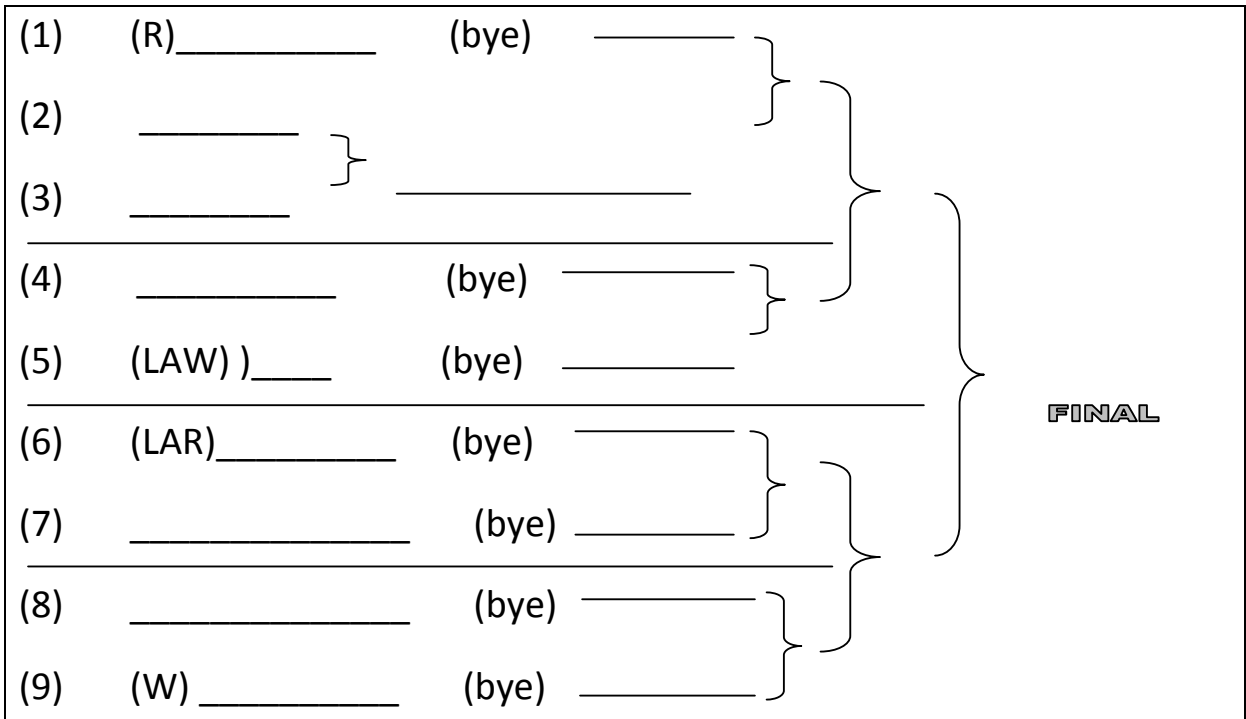

With 10 teams

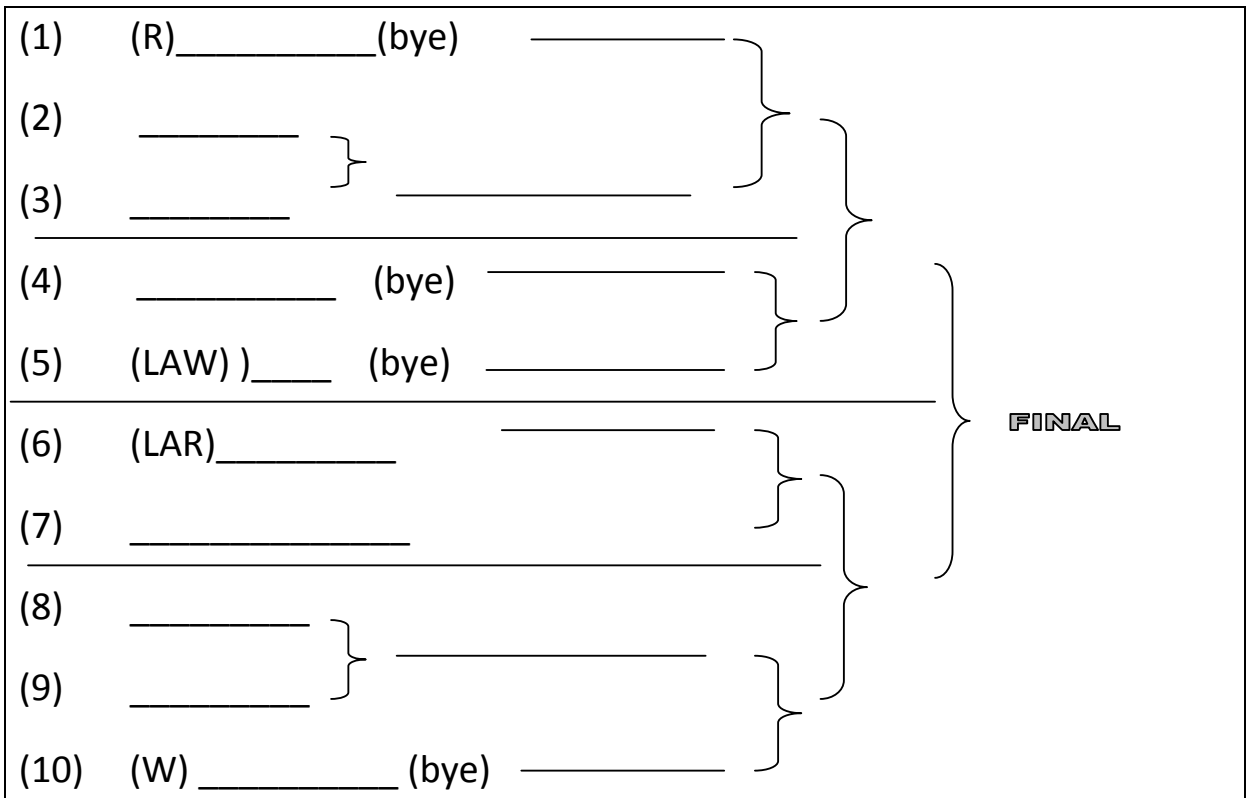

With 11 teams

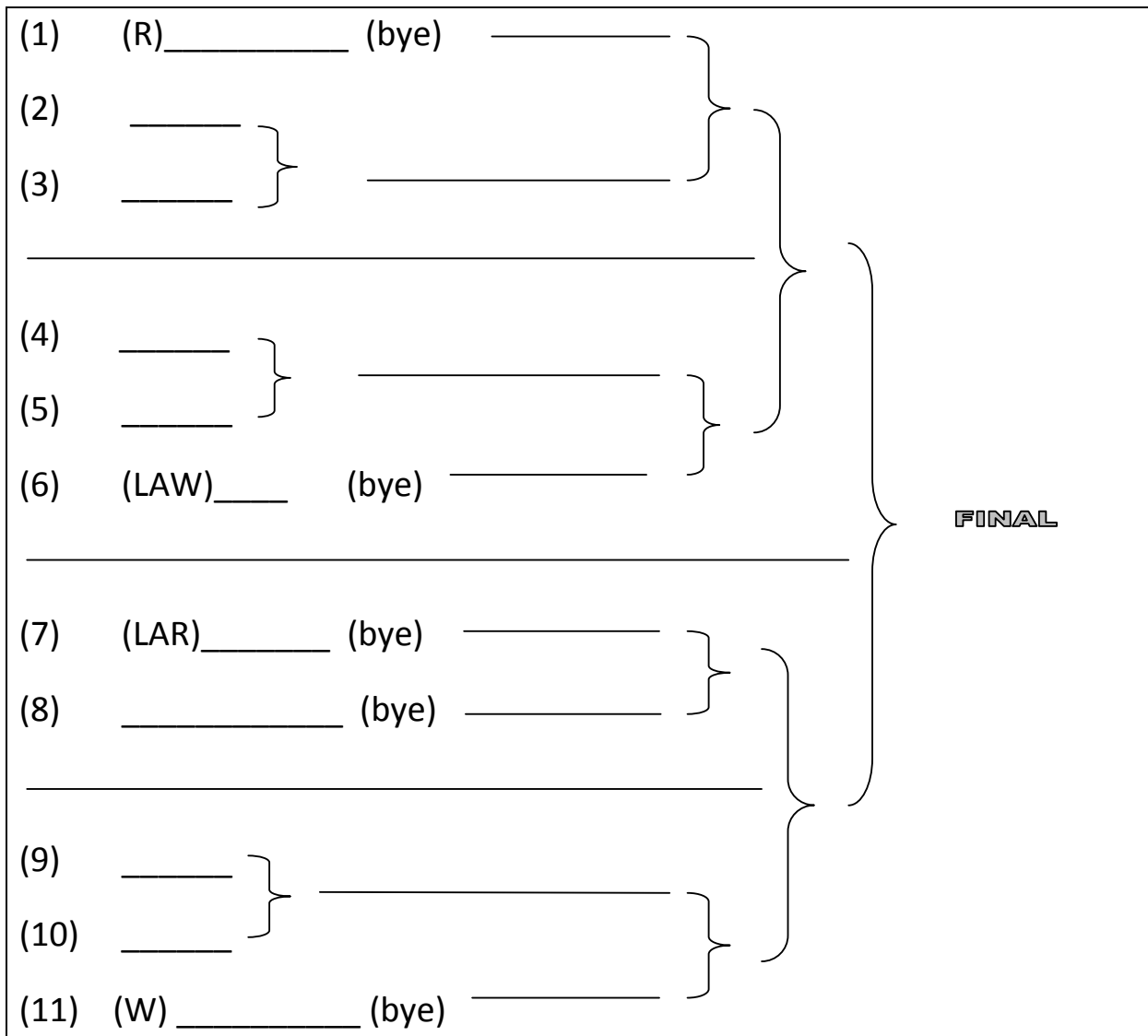

NOTE :- Loosing Semi-finalists of the Previous year shall be Cross Seeded.

Champions aren't made in gyms. Champions are made from something they have deep inside them: A desire, a dream, a vision. They have to have late minute stamina, they have to be a little faster, they have to have the skill and the will. But the will must be stronger than the skill." -

Muhammed Ali

Keep the 'Bye' on the numbers Written below**Numbers of Team Given the 'Bye' on Sequence the Number of the draw**

12	1,6,7 and 12
13	1,8 and 13
14	1 and 14
15	on 15
16	No 'Bye' will be given when teams are 16
17	1 and 4 to 17
18	1, 4 to 15 and 18
19	1 to 5, 8 to 13 and 18, 19
20	1, 4 to 7, 10 and 11, 14 to 17 and 20
21	1 to 3, 8 to 13 and 20, 21
22	1, 6 to 8, 11 and 12, 15 to 17 and 22
23	1, 6, 7, 12, 13, 18, 19, 20 and 23
24	1, 6, 7, 12, 13, 18, 19 and 24
25	1, 8, 13, 14, 19, 20 and 25
26	1, 8, 13, 14, 19 and 26
27	1, 14, 15, 20 and 27
28	1, 14, 15 and 28
29	1, 16 and 29
30	1 and 30
31	on 31
32	No Byes only seeding

Appendix - B

CEREMONIES

Methods & Procedures to conduct ceremonies Inter Collegiate Athletics Meet:

1	Opening Ceremony :	
(1)	March past of college teams in the-following-order: Band, committees, college representatives, college teams (Athletes) and-the Officials.	
(2)	Nominated captain of each college shall be the flag bearer of his college and lead his college team.	
(3)	Each team will form in to Twos (Two line formation) and shall be in the following order....First all the teams of different colleges and than other individual entry of the different athletes.	
(4)	The college shall be arranged in the alphabetical order but the winning team of the previous year shall lead and the Home Team shall bring up the rear.	
(5)	Dipping of flags by Captains and Olympic Salutes by all to the Tribune of Honor.	
(6)	Assembly of Athletes facing the Tribune of Honor.	
(7)	Declaration of the Athletic Meet open by the Tribune of Honor: "I proclaim the Annual Inter-College Athletic Meet of the Saurashtra University open."	
	વાર્ષિક ખેલકૂદ ખુલ્લો મૂકાયેલો	
(8)	Hosting of the University Flag.	
(9)	Oath taken by the Captain of the Home Team or best Athlete: "We swear that, we will take part in the Saurashtra University Inter College Athletics Meet respecting the regulations which-govern them and desirous of sportsmanship for the honor of our University and for the Glory of sports."	
(10)	Athletes and Officials march out to their enclosures in the reverse order.	
(11)	First event begins.....	
(b)	Closing Ceremony :	
(1)	March past as in opening ceremony.	
(2)	Assembly of Athletes as in opening ceremony.	
(3)	Speeches.	
(4)	Presentation of certificates and Challenge Trophies.	
(5)	Lowering of the Flag.	
(6)	Declaration of the Athletic Meet Sports and Tournaments closed by the Tribune of Honor. "I proclaim Saurashtra University Annual Athletic Meet– 2011 closed.	
	વાર્ષિક ખેલકૂદ	
(7)	Invitation to the next sports and tournaments (by the college representative concerned): "I call upon invites all the athletes of the Saurashtra of University to assemble at _____ College to participate in Annual Athletic Meet."	
	ખેલકૂદ	વાર્ષિક

"You win the race only after you cross the finish line, regardless of what place."

The Technical Officials' Oath

"In the name of all the officials, I promise that we shall officiate in Annual Athletics Meet -2011 with complete impartiality, respecting and abiding by the rules which govern them, in the true spirit of sportsmanship and glory of the sport" "Jay Hind"

The Athletes' Oath

(The following text shall be read by best Athletes during the opening ceremony of the Championships):

"In the name of all Athletes I promise that we shall take part in these Annual Athletics Meet 2011, respecting and abiding by the rules which govern them, committing ourselves to a sport without doping and without drugs, in the true spirit of sportsmanship, for the glory of sport and the honor of the Athletes." – "Jay Hind"

SPORTSMANSHIP

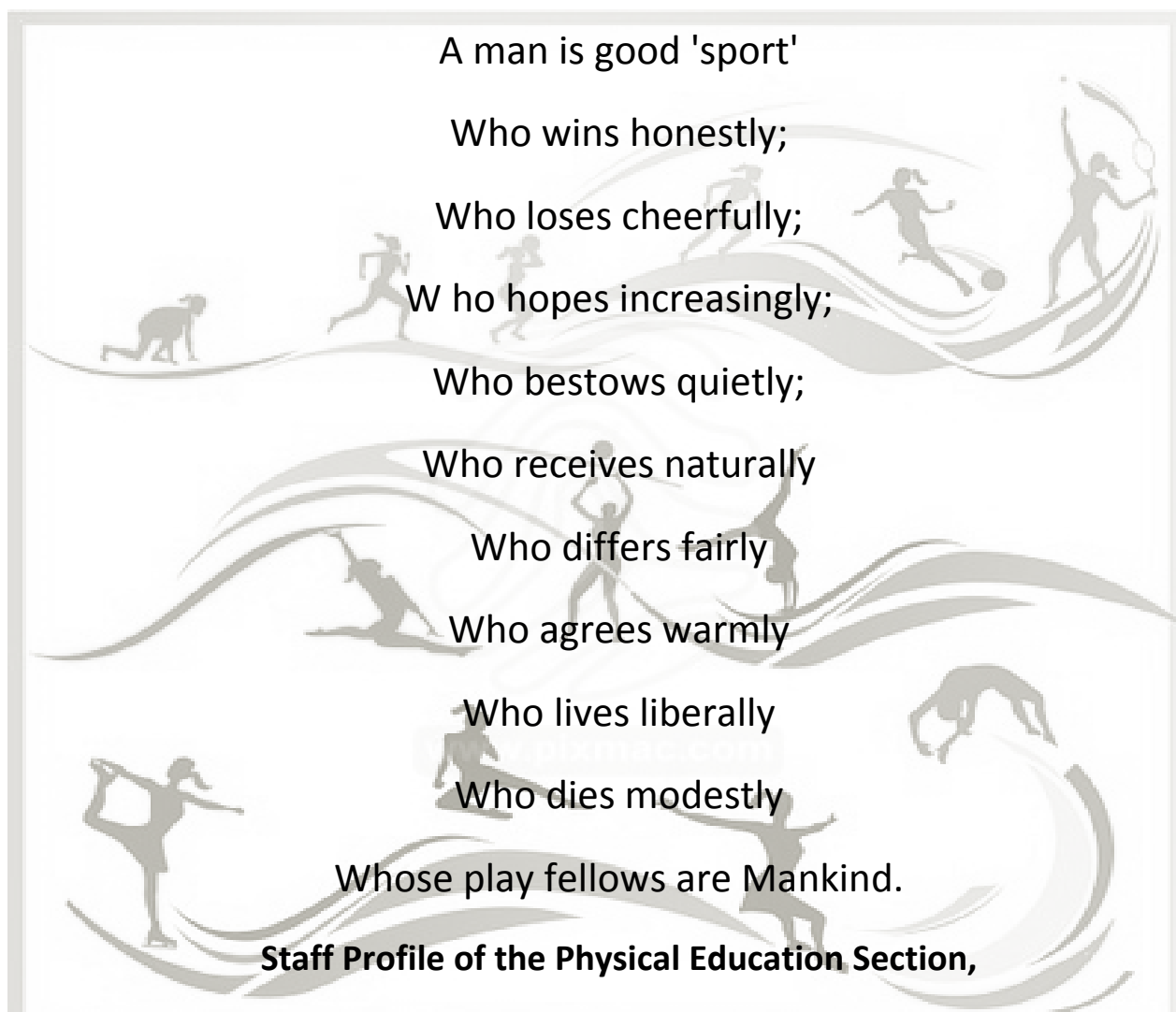

Saurashtra University, Rajkot



Sr. No	Name	Designation	Qualification	Date of Joining
1	Dr. Jatin H. Soni	Director of Phy. Edu. & Sports, Youth Affaires and Student Welfare	B.A.(Psy), M.A. (Psy), Dip. in Coaching (Gymn)., B.P.Ed., M.P.E., M. Phil.,Ph.D., FIG Judge (MAG) Sr. Club Coach B.G.A., U.K., CCC+	16/11/2009
2	Sh. Jivansinh P. Barad	Football Coach	B.Com., CCC+ Dip. in Coaching (Football)	
3	Sh. Harishbhai B. Raval	Section Officer	B.A., CCC+	01/01/1980
4	Sh. Deepakbhai J. Raval	Jr. Superintendent	B.Com., CCC+	30/04/1986
5	Sh. Jayesh R. Gosai	Clark cum computer operator Placement Staff	B.Com., CCC+	06/04/2009
6	Sh. Jentibhai K. Satani	Support Staff	7 th Std	01/01/1980
7	Sh. B.T. Noria	Ground Staff	7 th Std	03/09/1986
8	Sh. Deepakbhai Agrawat	Support Staff	8 th Std	03/09/1986

Those who truly have the spirit of champions are never wholly happy with an easy win. Half the satisfaction stems from knowing that it was the time and the effort you invested that led to your high achievement." ---Nicole Haislett

Saurashtra University, Rajkot



Director of Physical Education & Sports

Sr. No.	Name	Status	Period
1	Shri B. A. Lala		07/05/1967 to 24/10/1971
2	Shri R. J. Jadeja	I/C	25/10/1971 to 24/05/1979
3	Shri Dhirubhai Dobariya	I/C	25/05/1979 to 28/11/1980
4	Shri S. K. Patel		29/11/1980 to 31/10/2006
5	Shri J. P. Barad	I/C	01/11/2006 to 15/11/2009
6	Dr. Jatinkumar H. Soni		16/11/2009onwards

Contact Details:

Dr. Jatin H. Soni

Director of Physical Education and Sports

Physical Education Section,

Saurashtra University, Rajkot - 360 005 Gujarat (INDIA)

Phone: +91-281-2578501 extn.223 Fax: +91-281-2576347 / +91 281 2586983

Mo. 9099939474 /9426880474

Email: jhsoni@sauuni.ernet.in /jatin62@gmail.com /dpesur@gmail.com

Website: www.saurashtrauniversity.edu/

"The purpose of any athletic endeavor is to challenge human limits both on and off the playing field." - Dr. Jatin Soni